

SPECIFICATION

Customer : _____

Customer's Model No. : _____

Model No. : WD100 Series _____

Date : _____

Sample Serial No. : _____

Spec. Version & Revision Date: V02 2006.03.30 _____

Received/Approved by

CHAMPTEK[®]

Web : <http://www.champtek.com>

E-mail : sales@champtek.com

ChampTek Incorporated

5/F, No. 2, Alley 2, Shih-Wei Lane, Chung Cheng Rd.,
Hsin Tien City, Taipei, Taiwan, R.O.C.

Tel : 886-2-22192385

Fax : 886-2-22192387

Revision History

Version	Date	Context
V00	2004.04.22	Golden release
V01	2004.12.08	
V02	2006.03.30	

TABLE OF CONTENTS

A. General Description	4
B. Physical Characteristics	5
C. Electrical Characteristics	7
D. Performance.....	8
E. Environmental	8
F. Readable Symbologies	8
G. Pin Assignment	9
H. Reliability	10
I. Packing	10

A. General Description

This wand is a portable hand-held barcode reader that is specially designed to provide the best scanning result. Much of attention is focus on the high quality optical module as well as the efficient electronic circuits to minimize the power consumption. Since current drawn is reduced, it is very suitable for portable or battery operated environment where run time is a very important issue. With different wavelengths, barcodes which



are printed on different materials can be easily read to suit the application needs. The high resolution model guarantees the best first read rate for high density codes in the industry.

B. Physical Characteristics

Weight

Body weight	Approx. 4.594 oz (130 gm)
Cable weight	Approx. 2.65 oz (75 gm)

Material

Metal

Connector

WAFER 90°3 Pins

Dimension

149.2 mm X 13.5 mm

Cable Length	82 cm (32.3 inch)
--------------	---------------------

a) cable

unit : mm

1) TTL

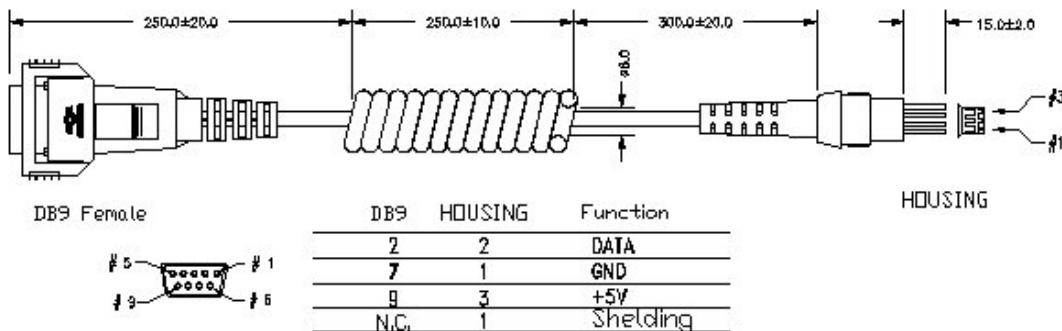

2) RS232

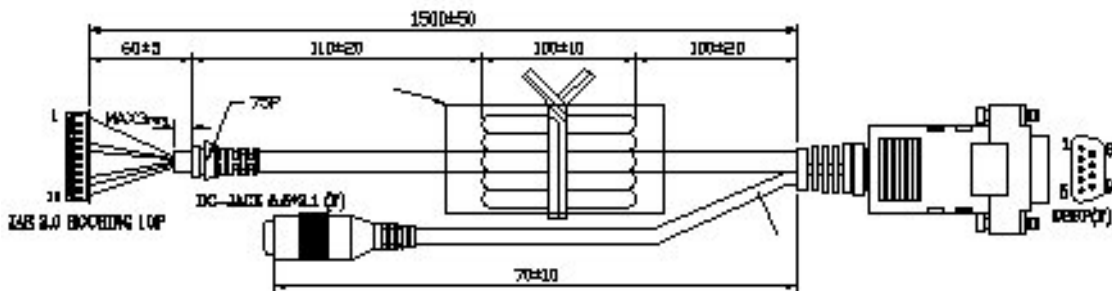

3) Keyboard

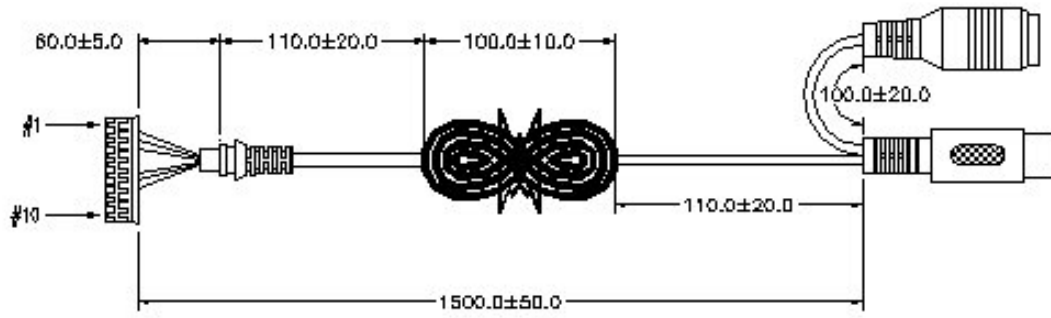

4) USB

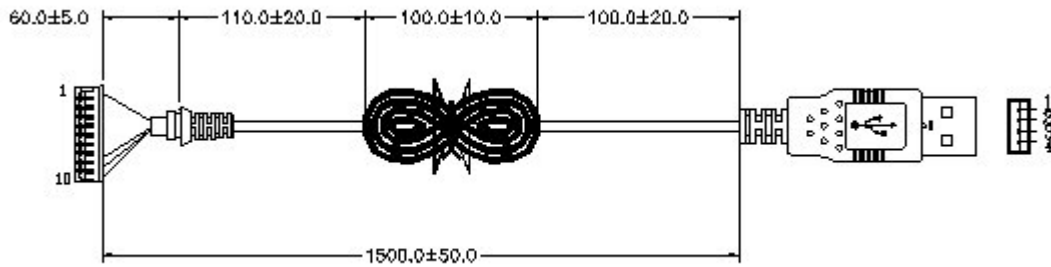

b) Mechanical drawing

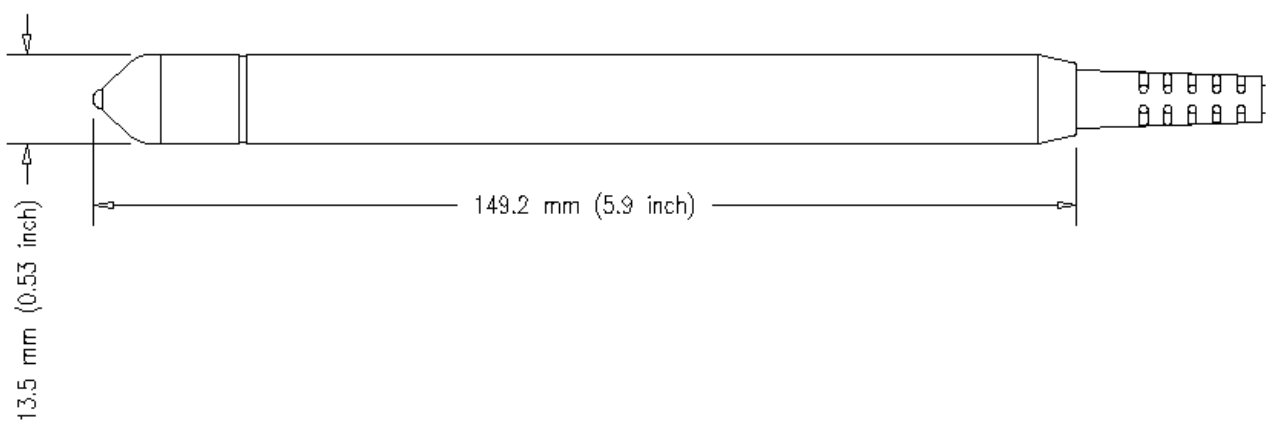

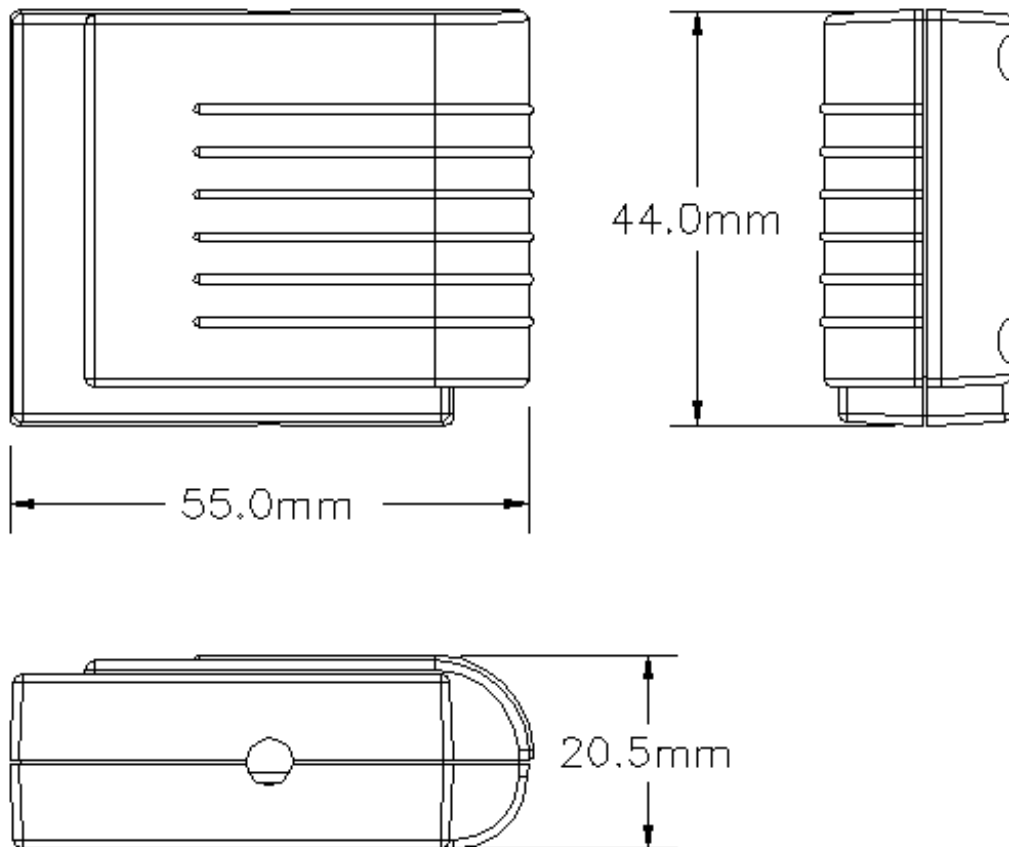

C. Electrical Characteristics

Interface	TTL	RS232	KB	USB
Supply Voltage		DC +5V	±5%	
Output Voltage (Typ.)	+5V ±5%	±9V	+5V ±5%	+5V ±5%
Output low Voltage (Max.)	0.4V	-	0.7V	0.7V
Current Draw		±10%		
Power On (Typ.)	-	70mA	65mA	70mA
Stand by (Typ.)	-	50mA	45mA	50mA
Operation (Typ.)	20mA	65mA	55mA	60mA

D. Performance

	WD10X-X	WD11X-X
Light Source	Visible Red light 660nm LED	infrared light 940nm
Sensor		Photo Diode
Scan Speed		50 - 500 mm / sec
Depth of Field		Contact Type
Resolution		5mil/0.127mm@PCS90%
Scanning Angle		± 45 ° (±5°)
Ambient Light		1500 Lux Max. (Sunlight)

E. Environmental

Operating Temperature	0 °C to 50 °C (32 °F to 122 °F)
Storage Temperature	-20 °C to 70 °C (-4 °F to 158 °F)
Relative Humidity	20% to 95% (Non-condensing)

F. Readable Symbologies

	Readable	Default Enable
All UPC/EAN/JAN	V	V
EAN128 Code	V	V
Code 39	V	V
Code 39 Full ASCII	V	
Code32 / Italian Pharmacy	V	
Code 128	V	V
CODABAR/NW7	V	V
Interleave 25	V	V
Industrial 25	V	
Matrix 25	V	
MSI/PLESSEY	V	
Telepen	V	
Code 93	V	
Code 11	V	
China Postage	V	

G. Pin Assignment

a) Keyboard Interface

DIN 5 MALE

Pin No.	Function
1	HOST CLK
2	HOST DATA
4	GND
5	Vcc(+5V)

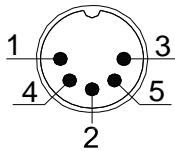

DIN 5 FEMALE

Pin No.	Function
1	KB CLK
2	KB DATA
4	GND
5	Vcc(+5V)

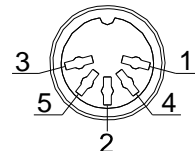

MiniDIN 6 MALE

Pin No.	Function
1	HOST DATA
3	GND
4	Vcc(+5V)
5	HOST CLK

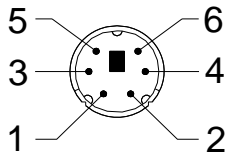

MiniDIN 6 FEMALE

Pin No.	Function
1	KB DATA
3	GND
4	Vcc(+5V)
5	KB CLK

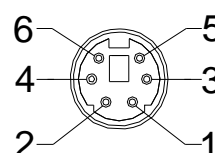

b) RS232 Interface

DB 9 Female

Pin No.	Function
2	TXD
3	RXD
5	GND
7	CTS
8	RTS
9	Vcc/+5V
Power Lead	Vcc/+5V

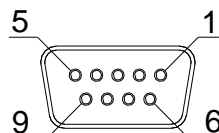

c) USB Interface**USB A Type Male**

Pin No.	Function
1	Vcc
2	D-
3	D+
4	GND

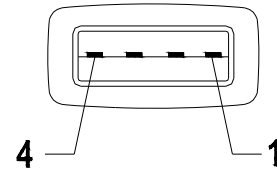
**H. Reliability****Life Time**

Light Source	40,000 hours
MTBF(Calculated)	80,000 hours

Thermal Shock

High Temp.	70 °C (140 °F)
Low Temp.	-20 °C (-4 °F)
Cycle time	20 minutes for high temp. , 20 minutes for low temp.
Cycles	5 cycles

Cable Bending Test 25,000 times minimum (30 times/min @ 500g/90°)

Mechanical Shock 40 inch (100 cm) Drop on Concrete Surface

I. Packing**Dimension**

Unit	3.2 cm X 10 cm X 21.4 cm
Carton	25 cm X 35 cm X 52 cm

Weight

Unit	365 g
Carton	8 Kg (Q'ty :20 pcs)

Storage

Temperature	-20 °C to 70 °C (-4 °F to 140 °F)
Humidity	20% to 95% (Non-condensing)

Unit : CM

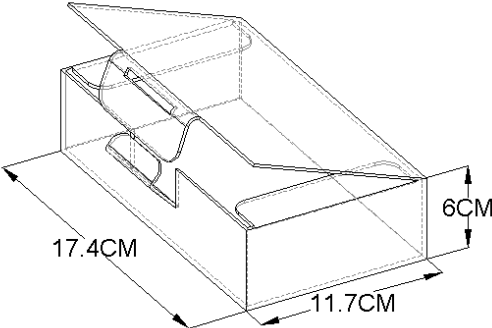

Carton :

